

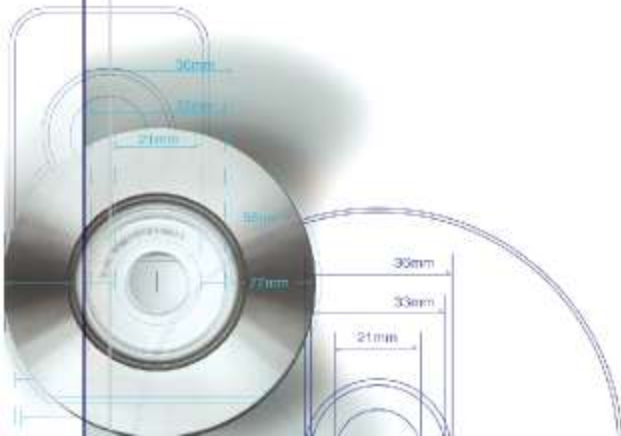

- The **DISCS ON DEMAND** system is a complete solution for transferring from live **TV to DVD.**
- Orders for the broadcasted programs may be placed through the broadcaster's website and automatically produced, charged and mailed by **DISCS ON DEMAND.**

**DISCS ON DEMAND**





# Why not just download?

YES VIDEO™



- Downloading video is great, but with limitations, especially for the technically challenged.
- Streaming a video is great, but a 2" or larger picture does not show the full video experience, and it can only be seen on a computer. There will be some time before bandwidth is sufficient to allow high quality real time video downloading.

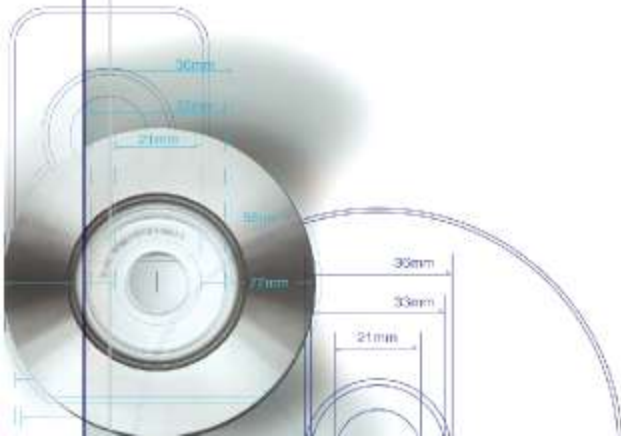

**DISCS  ON DEMAND**



YES VIDEO™



# Yes but I can always record myself!

- PVR, IQ and VCR are great, provided the viewer remembers to set the recorder, or was even aware that the program was going to be broadcast.

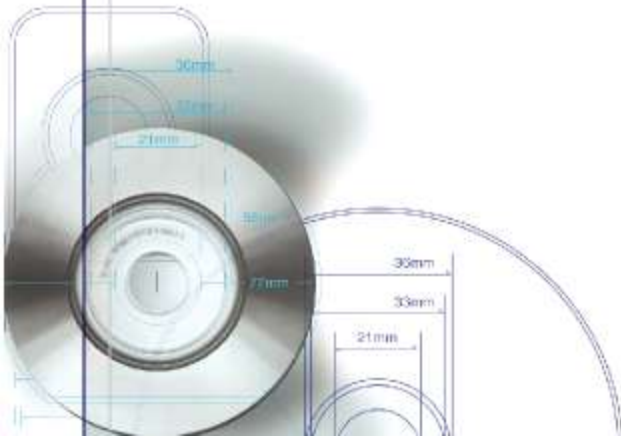

**DISCS  ON DEMAND**



YES VIDEO™



# What Consumers Want

Desired Activities Using Household TVs

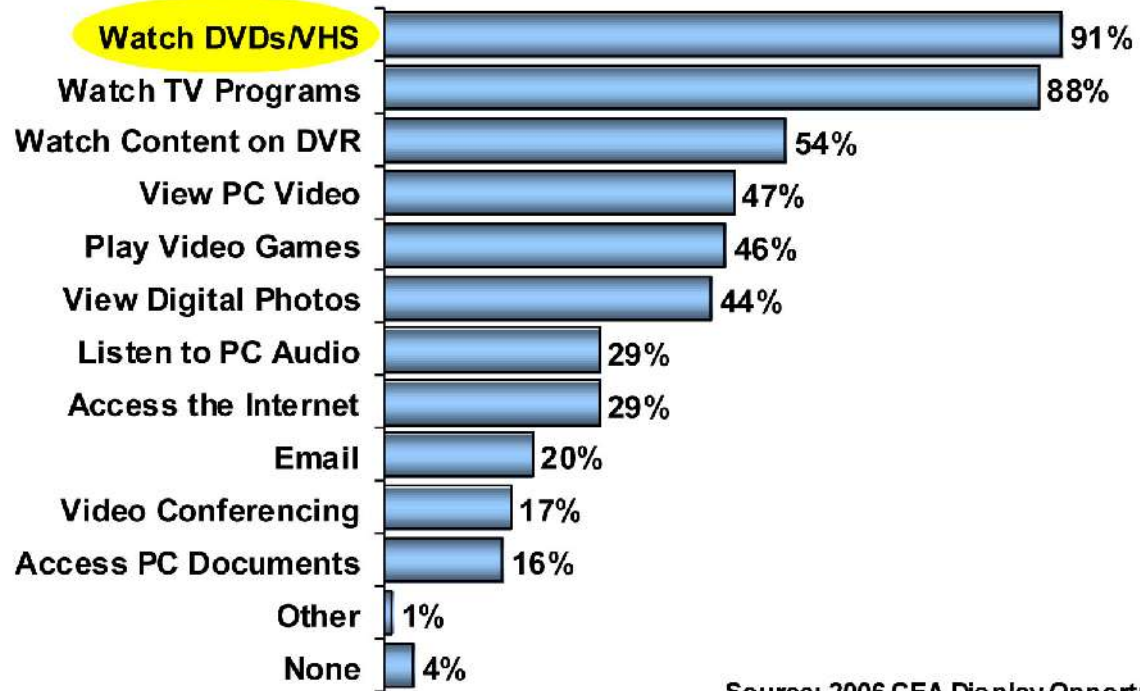

Source: 2006 CEA Display Opportunities Study

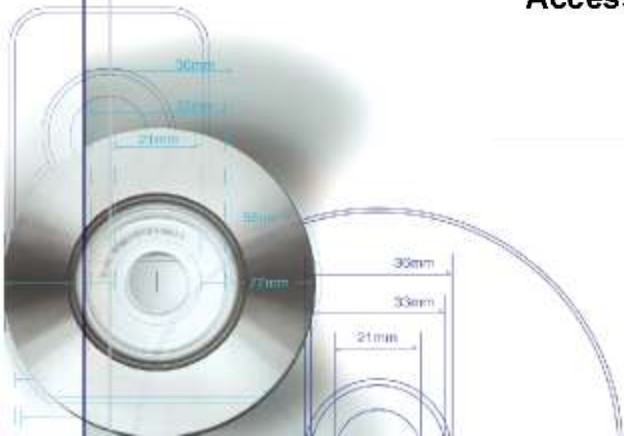

**DISCS ON DEMAND**



YES VIDEO™



# So where are they looking?

- There is a demand for previously broadcast video, presently mainly available only through illegal downloading by growing technologies such as Usenet, Bit Torrent, eDonkey and eXeem.
- This inability to satisfy a need is a threat to video as much as the internet has negatively impacted the music industry due to its slow and rigid response to changing technology.

**DISCS  IN DEMAND**

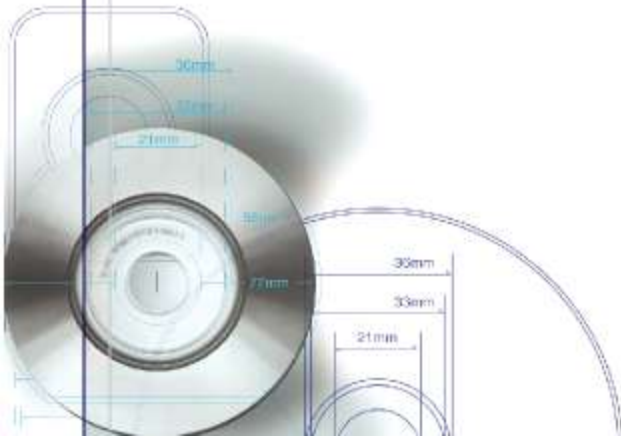



YES VIDEO™



# One new solution!

- **DISCS ON DEMAND** can supply MPEG-2 quality DVD copies of any program that has been broadcast within a day of broadcast, charging the viewer and then posting.

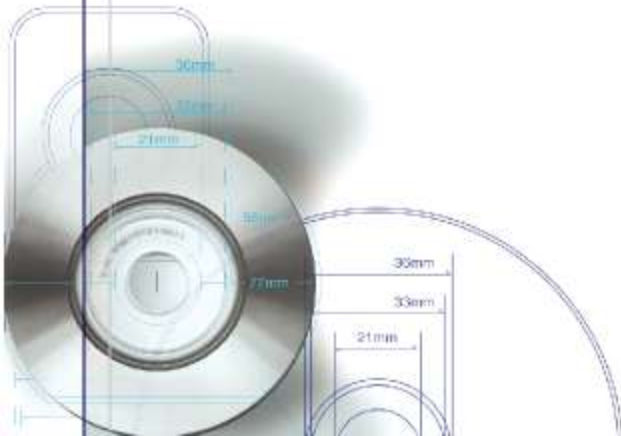

**DISCS ON DEMAND**



YES VIDEO™



## How much can this cost?

- **DISCS ON DEMAND** can charge \$4.95 for shipping and handling, \$5 for the disc and \$5 per hour of video, giving \$14.95 for 1 hour of video, or \$19.95 for 2 hours of video.

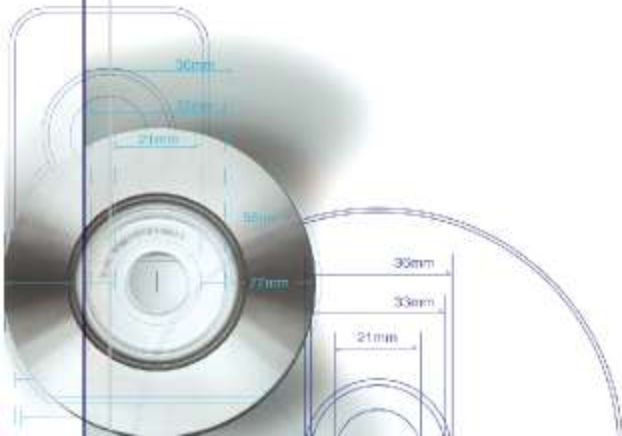



**DISCS ON DEMAND**



YES VIDEO™



# The Broadcaster does nothing, but give permission!

- **DISCS  N DEMAND** offers the service of arranging the entire production, supplying all materials and system, with the GROSS amount split between the **DISCS  N DEMAND** and the broadcaster.

**DISCS  N DEMAND**

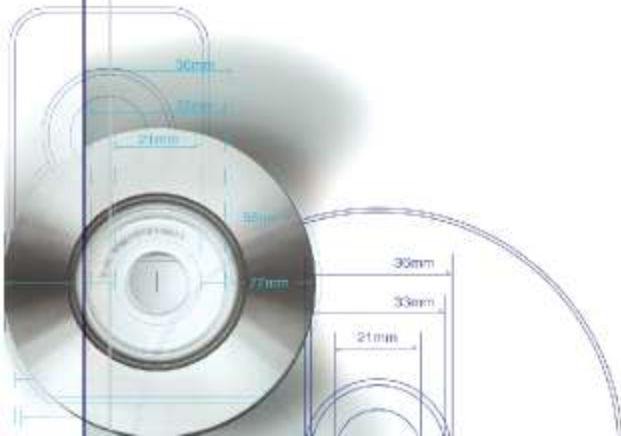



YES VIDEO™



# Extra features

- Each DVD can combine two or more programs on one DVD, to two hours per DVD, offering even better value.
- The viewer will be able order a whole series in advance, and have it shipped as requested.

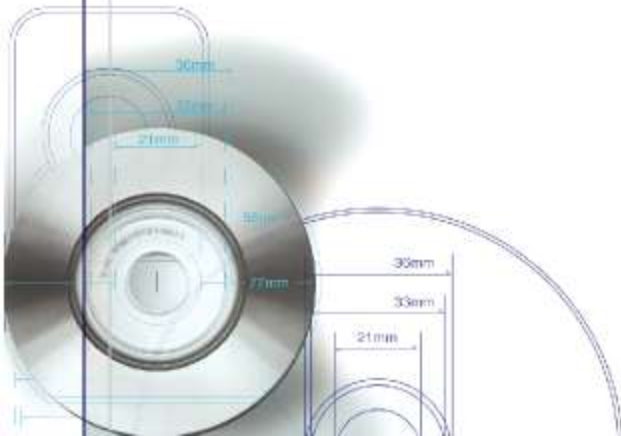

**DISCS  ON DEMAND**



YES VIDEO™



# Be communally responsible!

- **DISCS ON DEMAND** can offer flexible charging rates, such as reduced prices for public interest programs.

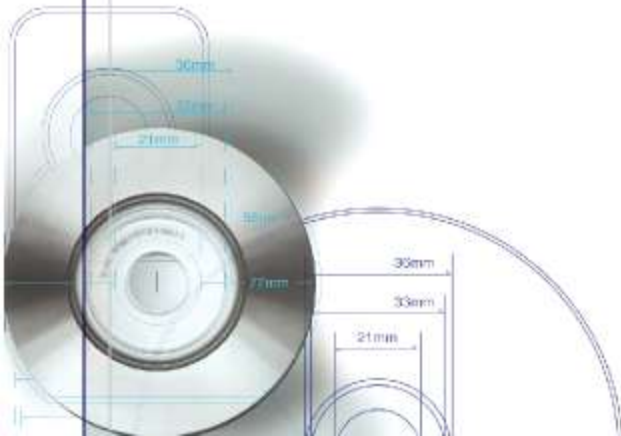

**DISCS  N DEMAND**



YES VIDEO™



## And there's more!

- It is not necessary to remove the **advertising**.
- So not only do advertiser's increase their exposure, but the Broadcaster has the possibility to charge for this extra exposure.

**DISCS  ON DEMAND**

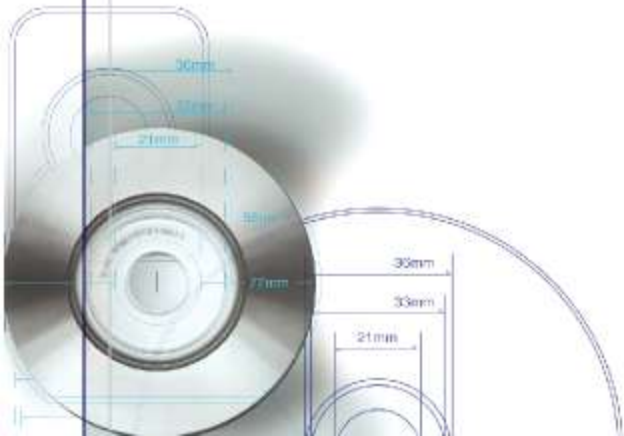



# We operate only legitimately!

YES VIDEO™



- **DISCS ON DEMAND** would only offer the service for material that can **legally** be on-sold on DVD.
- The Broadcaster would have total control over which programs are made available.

**DISCS ON DEMAND**

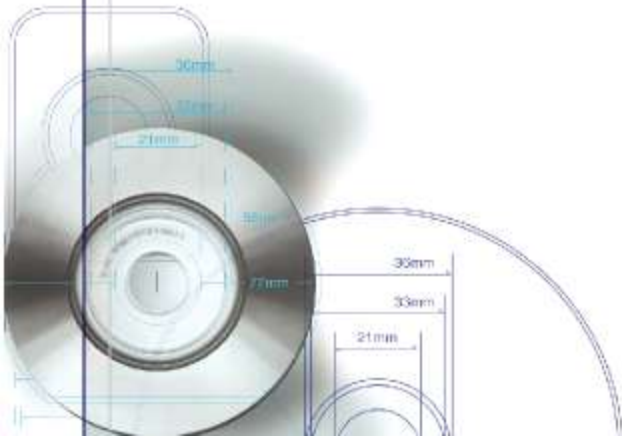



YES VIDEO™



# The capacity is here!

- **DISCS ON DEMAND** have a huge **capacity**, and are able to produce over 500 customised DVDs an hour.
- As an example, with proper planning it would have been possible to post 2,000 copies of Prime Minister Kevin Rudd's apology that evening to schools, and thousands more the next day.

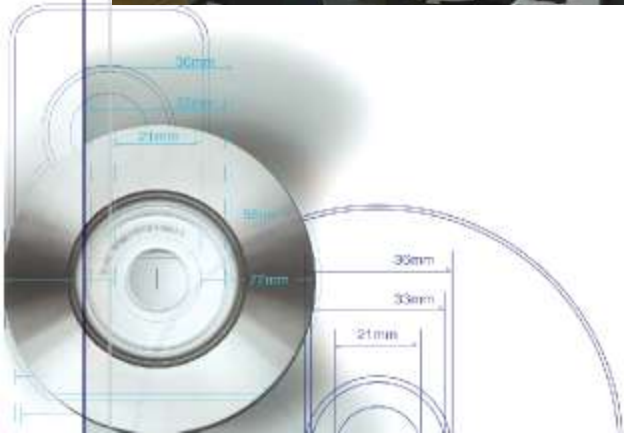

**DISCS ON DEMAND**



YES VIDEO™



# New technologies

- Discs-on-Demand Pty Ltd are leaders in new technologies, and can offer video on Blu-ray, or even USB or SD cards, having supplied software for card duplication worldwide.

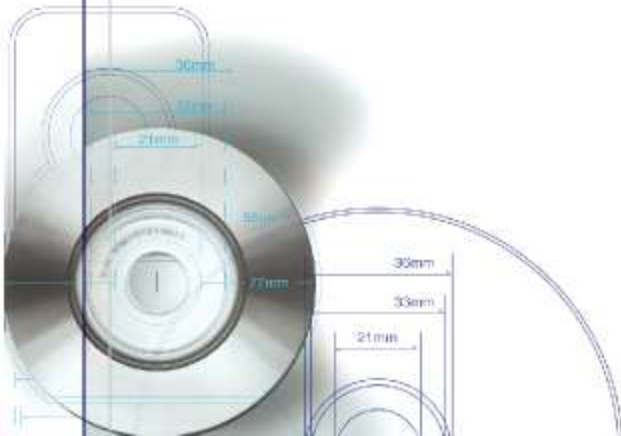

**DISCS  ON DEMAND**



YES VIDEO™



FORTIUM



# Copy Protection is available

- Discs-on-Demand Pty Ltd is able to include very high grade Digital Rights Management technology – Copy Protection - on each disc.
- These technologies are far superior to the “cracked” CSS system used on commercial DVDs.

**DISCS  ON DEMAND**



# More opportunities

YES VIDEO™



- A future service will be the ability to offer video on SD cards, so that a viewer will be able to buy a video on a SD card, and view it at their leisure.
- With write once cards expected to cost a dollar by years end, this opens a new market for viewing video.

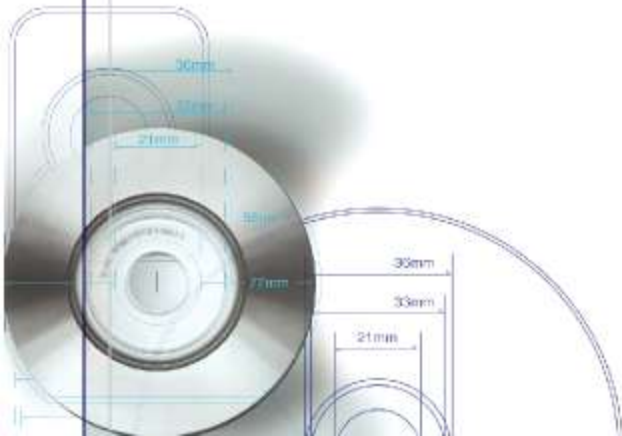

**DISCS  ON DEMAND**